

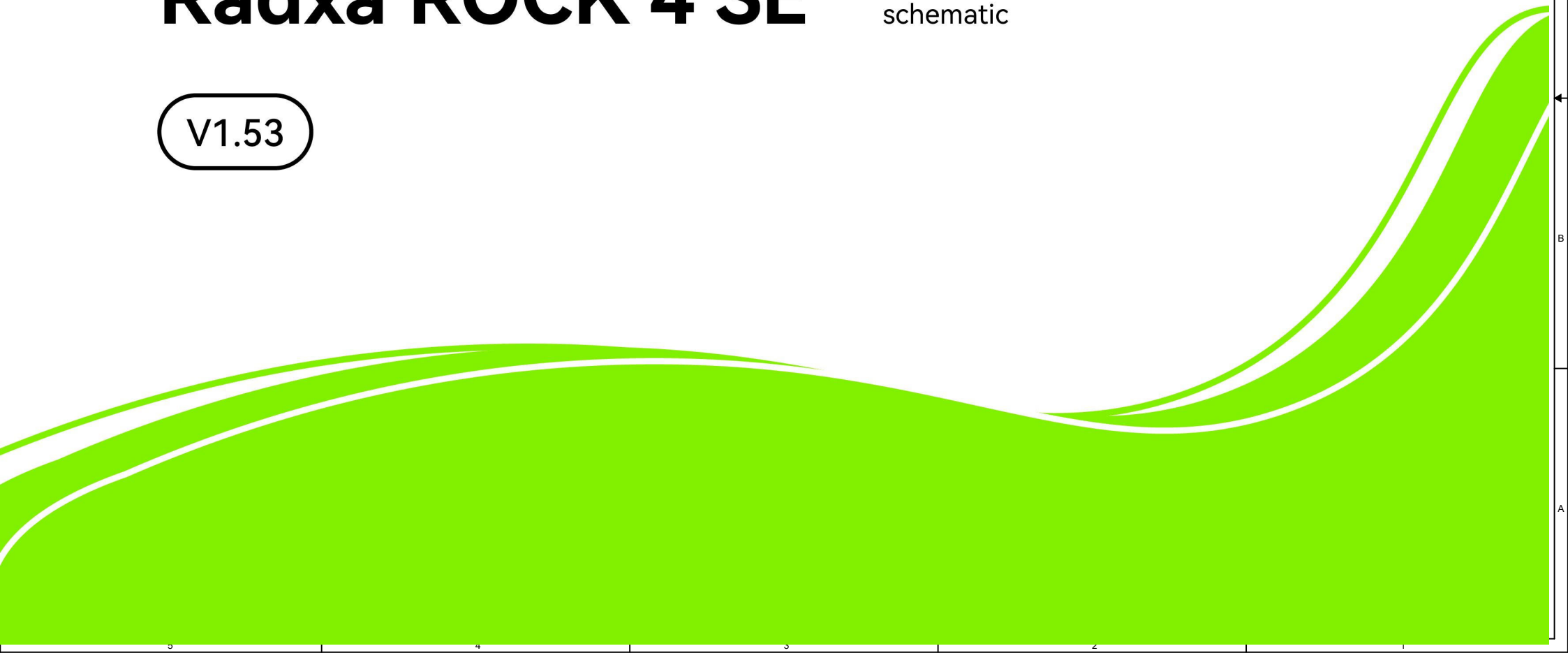

# Radxa ROCK 4 SE

schematic

V1.53



## CONTENT INDEXING

- 01.Cover page
- 02.Index
- 03.Block Diagram
- 04.ES8316
- 05.CONNECTOR
- 06.RK3399 Power
- 07.RK3399 PMU Controler
- 08.RK3399 DDR Controler
- 09.RK3399 Flash&SDMMC Controler
- 10.RK3399 USB/USIC Controler
- 11.RK3399 SARADC/Key
- 12.RK3399 DVP Interface
- 13.RK3399 Display Interface
- 14.RK3399 GPIO
- 15.RK3399 PCIE
- 16.Power-DC IN
- 17.Power-PMIC RK808-D
- 18.RTL8211F
- 19.USB3.0 OTG Port
- 20.RAM-LPDDR4(200P)
- 21.Memory-EMMC
- 22.WIFI/BT AP6255
- 23.TF Card
- 24.HDMI Output
- 25.PCie NGFF/M.2
- 26.FAN-KEY-LED
- 27.Hole



Size	Title: <b>ROCK 4 SE</b>	REV
<b>A4</b>	Page Name: <b>Index</b>	<b>1.53</b>
Date: <b>Thursday, October 27, 2022</b>	Sheet <b>2</b> of <b>27</b>	

# Block Diagram

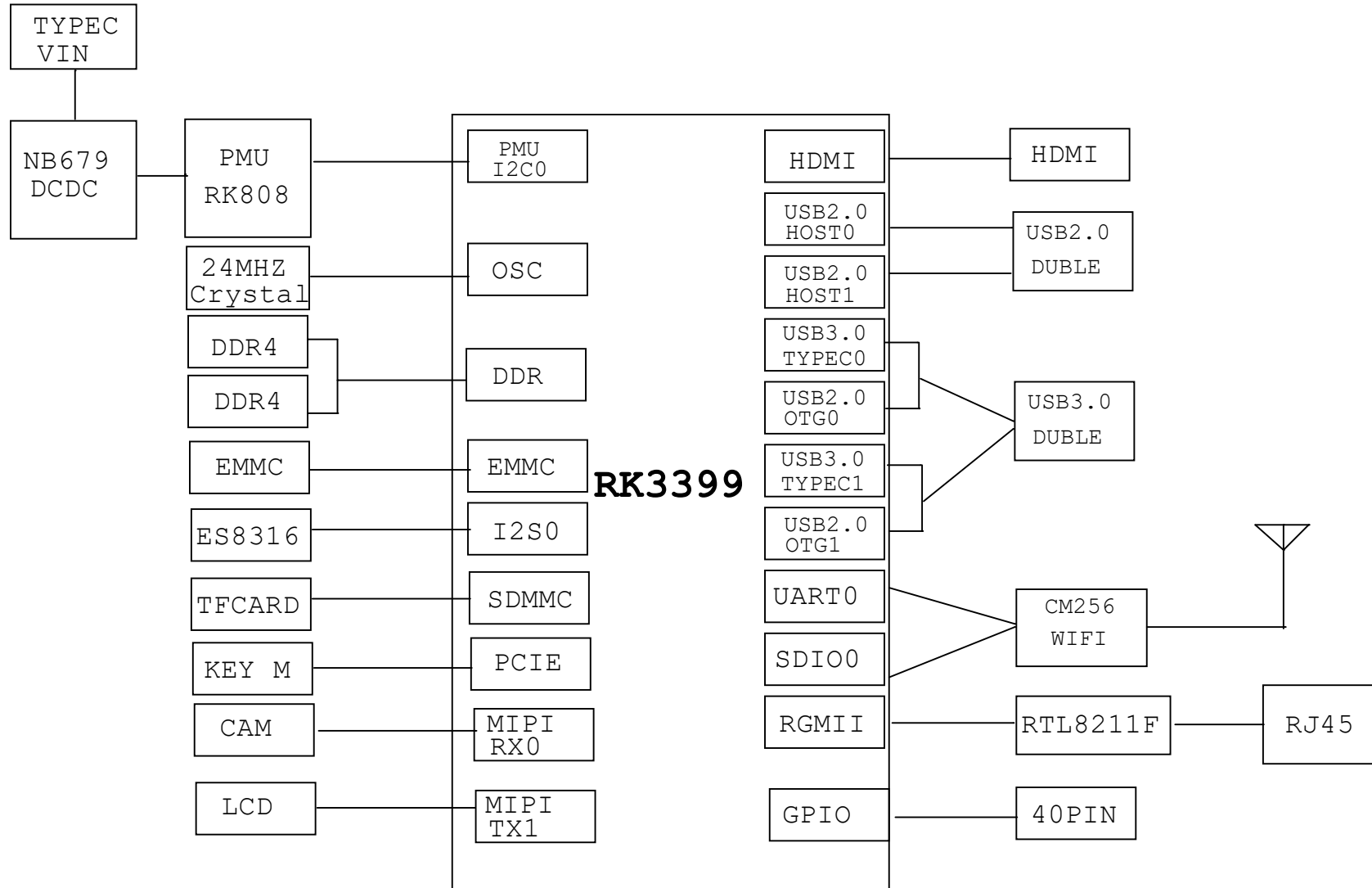

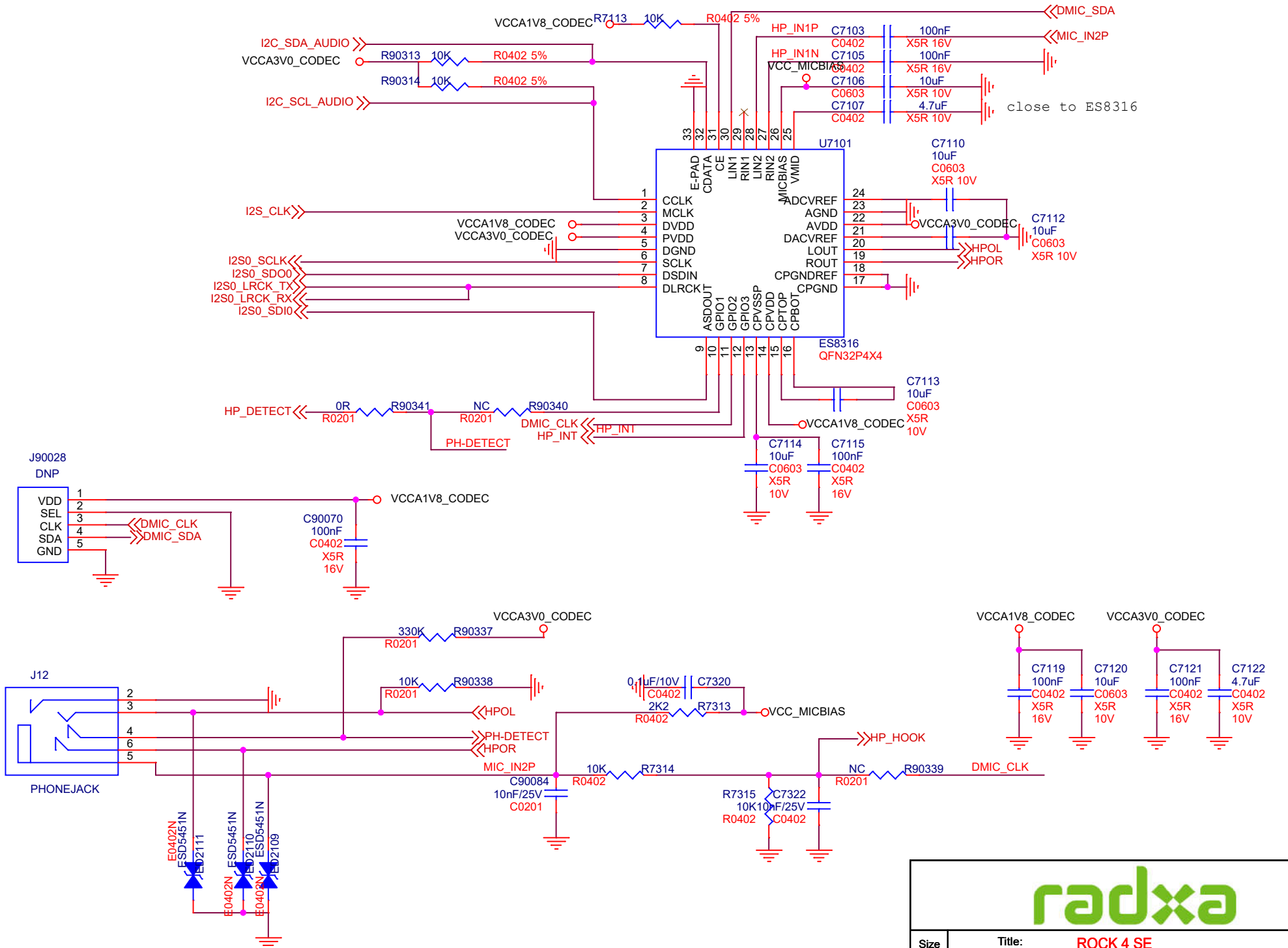

**radxa**

Size	Title: <b>ROCK 4 SE</b>	REV
A4	Page Name: <b>ES8316</b>	1.53
Date: <b>Thursday, October 27, 2022</b>		Sheet <b>4</b> of <b>27</b>



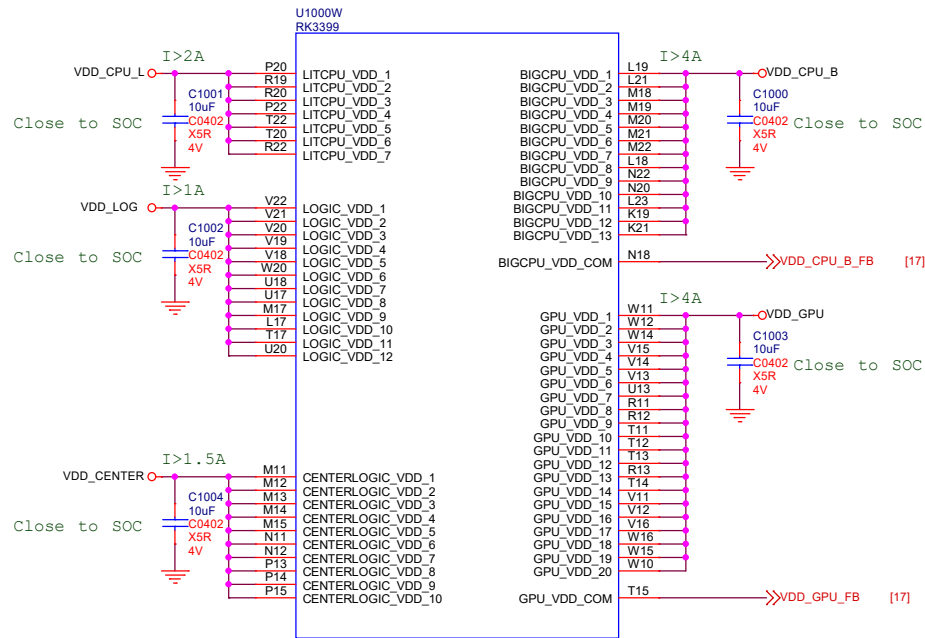

Note: Power filter CAP please place back of SOC or close to SOC

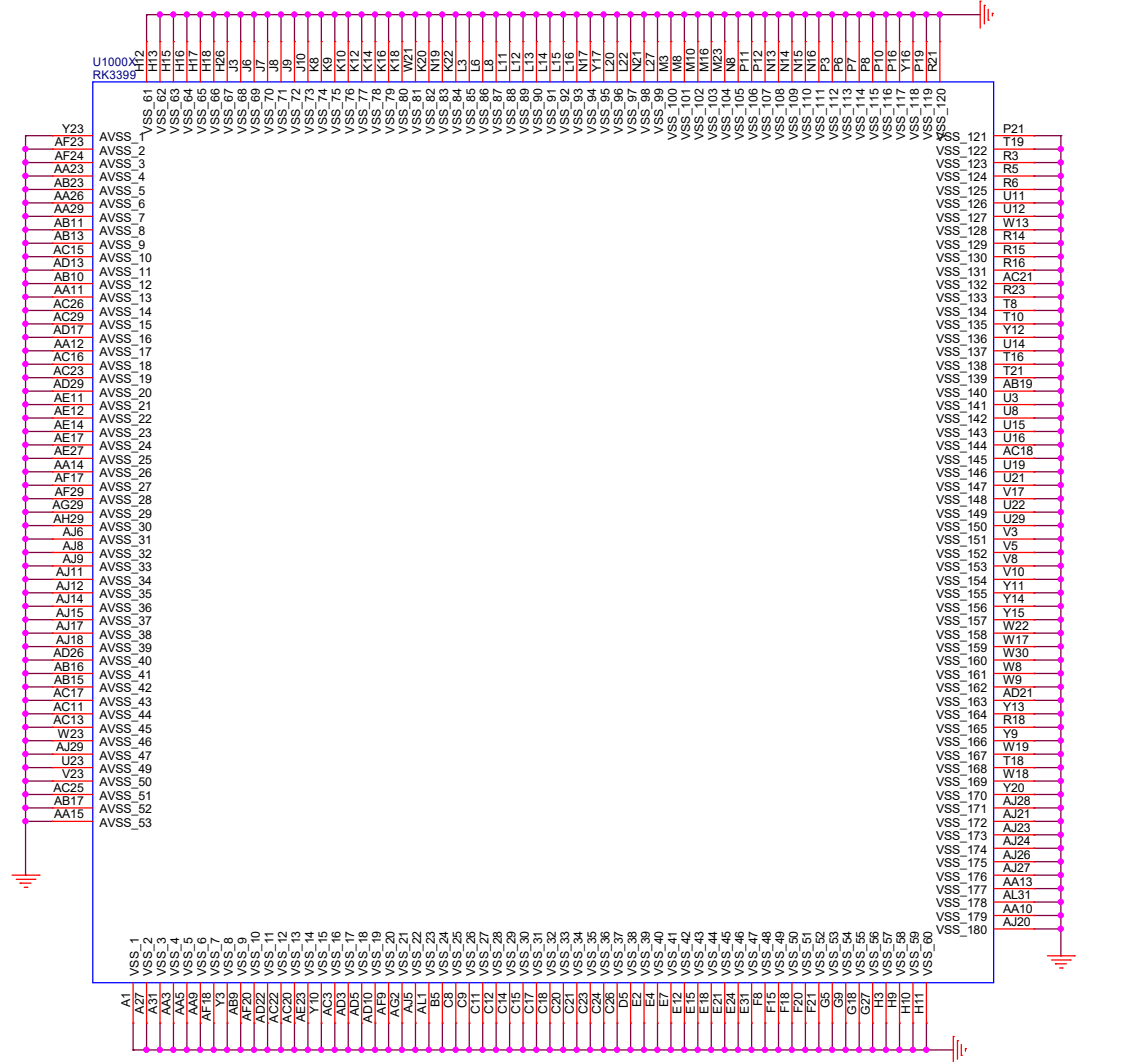
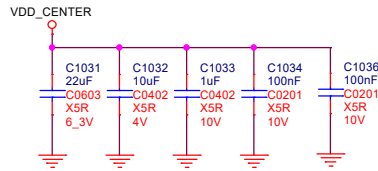
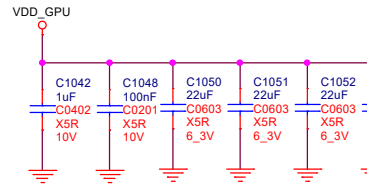
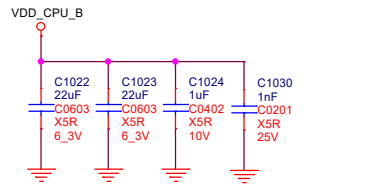
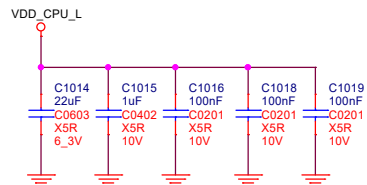
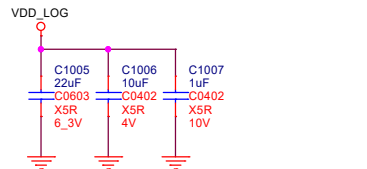

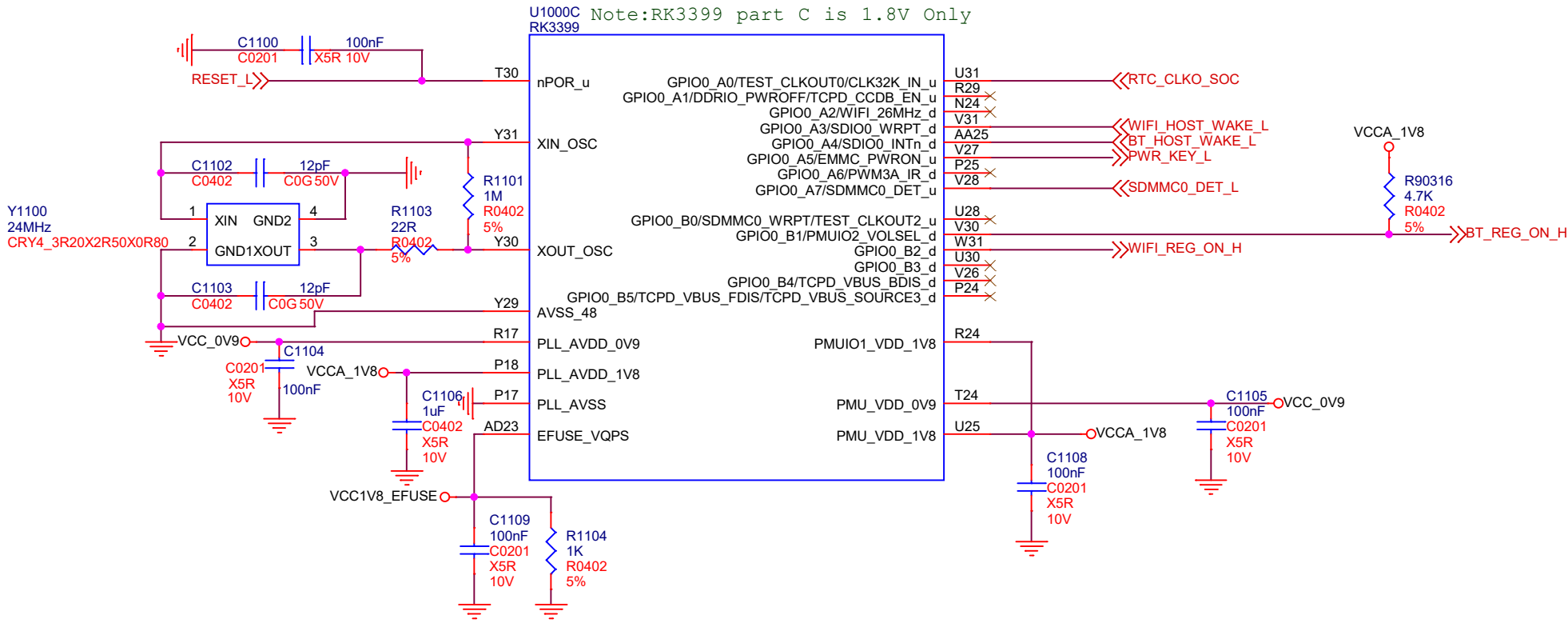

Size	Title: <b>ROCK 4 SE</b>	REV
A4	Page Name: <b>RK3399 PMU Controller</b>	1.53
Date: <b>Thursday, October 27, 2022</b>	Sheet <b>7</b> of <b>27</b>	

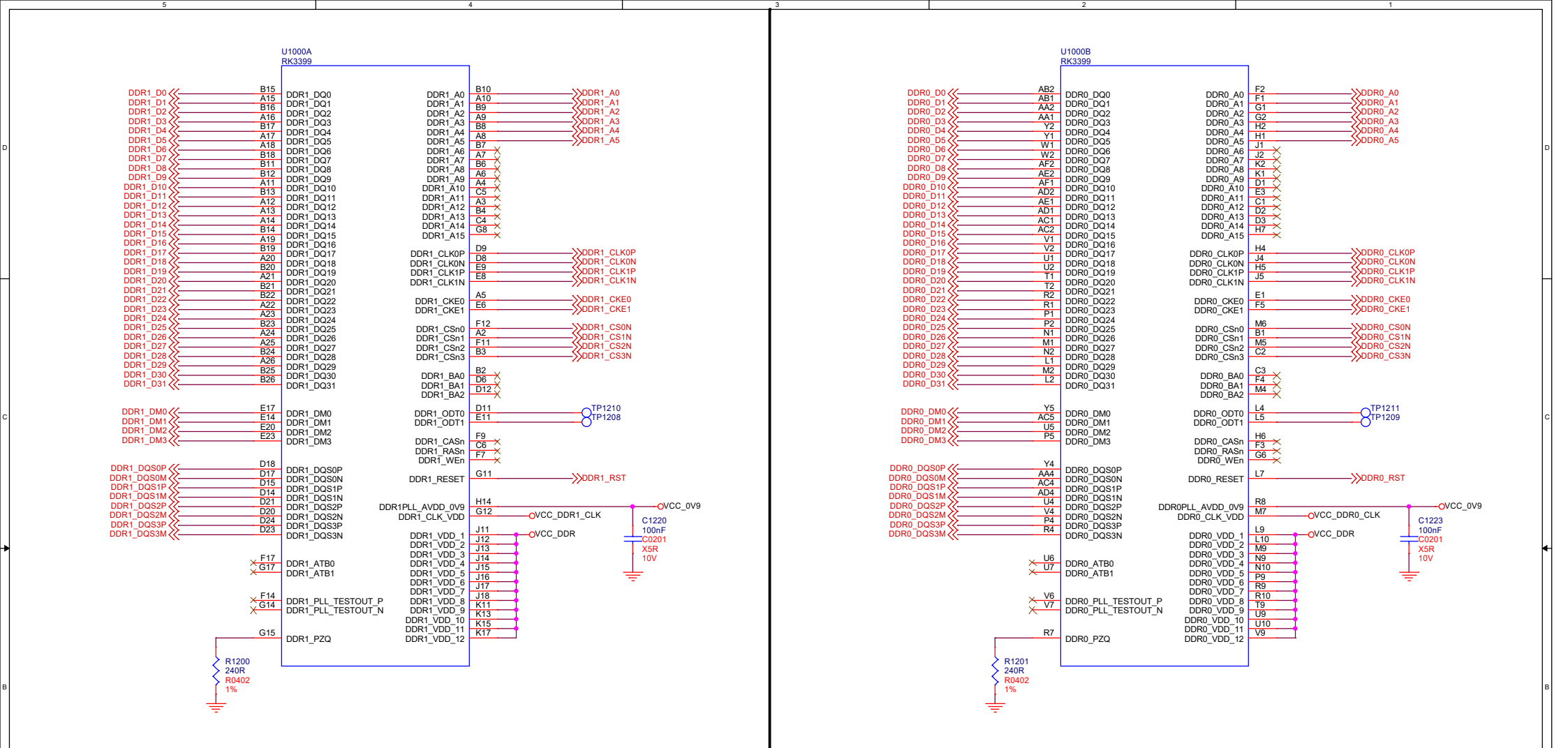

DDR FILTER Note:R1202 cannot be deleted

DDR FILTER Note:R1203 cannot be deleted

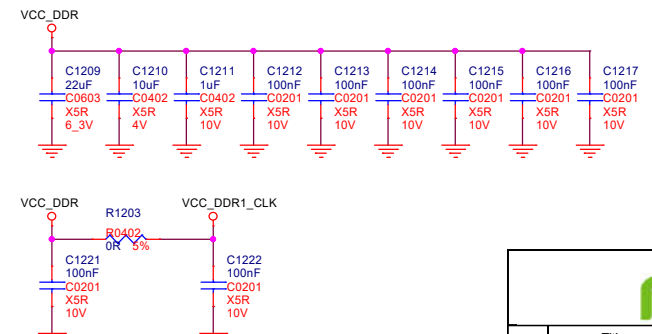
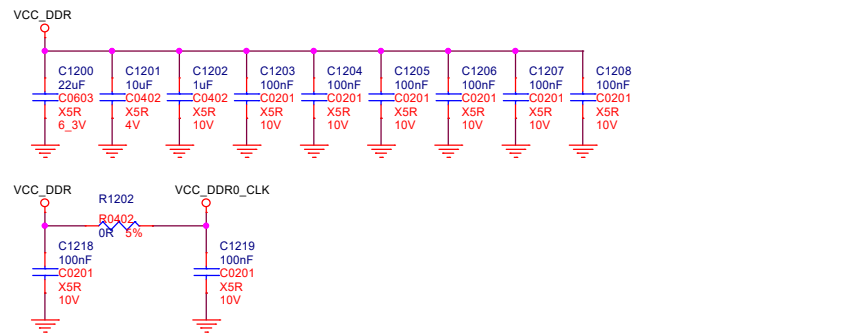

**radxa**

Size	Title:	ROCK 4 SE	REV
A3	Page Name:	RK3399 DDR Controller	1.53
Date:	Thursday, October 27, 2022	Sheet	8 of 27



U1000H  
RK3399

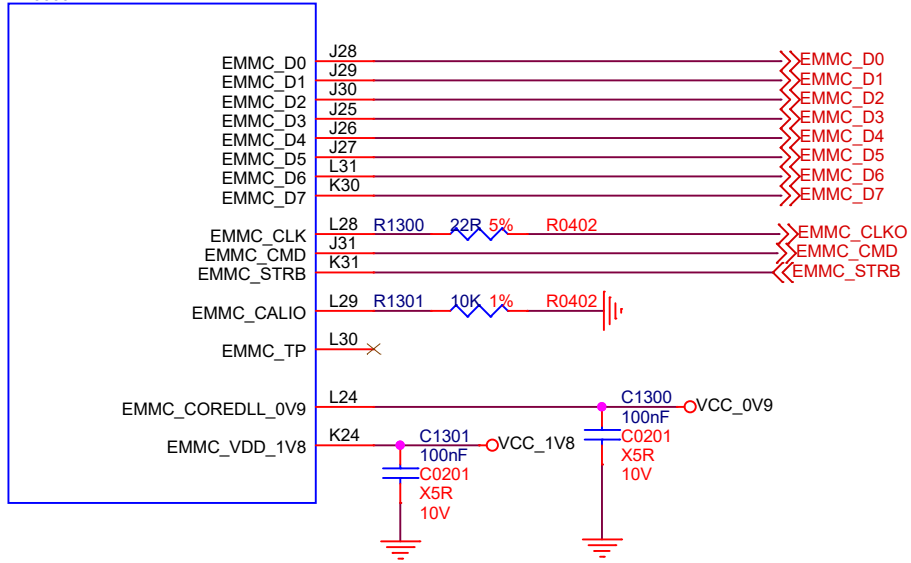

U1000F  
RK3399

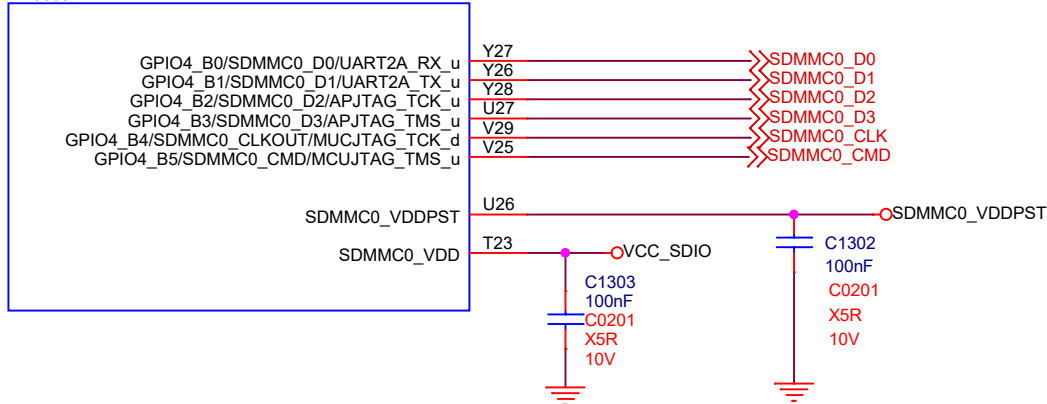

Size	Title: <b>ROCK 4 SE</b>	REV
A4	Page Name: <b>RK3399 Flash&amp;SDMMC Controller</b>	1.53
Date: <b>Thursday, October 27, 2022</b>	Sheet <b>9</b> of <b>27</b>	

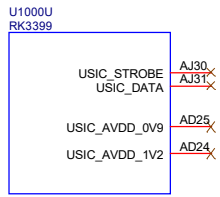

## USB2.0

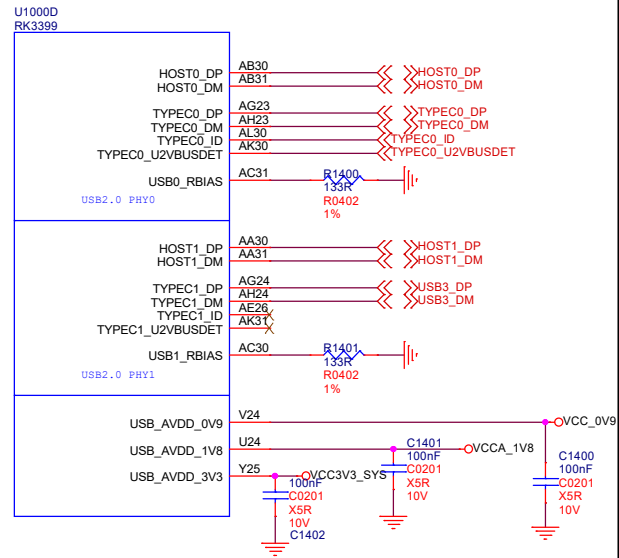

## USB3.0

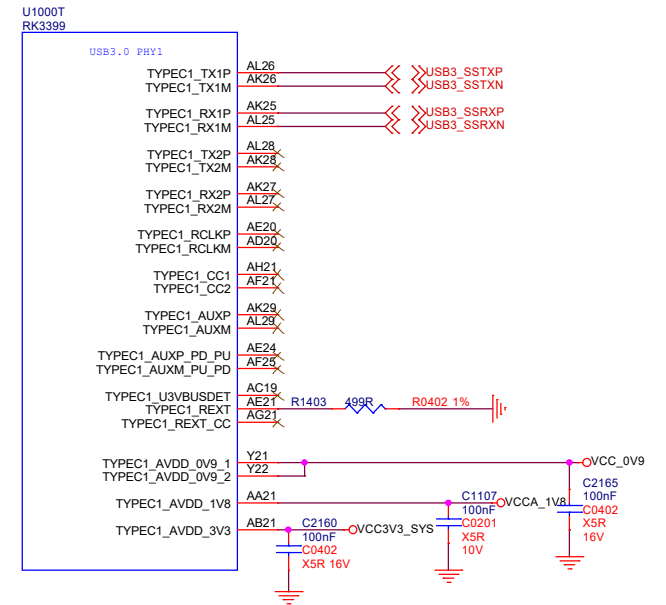
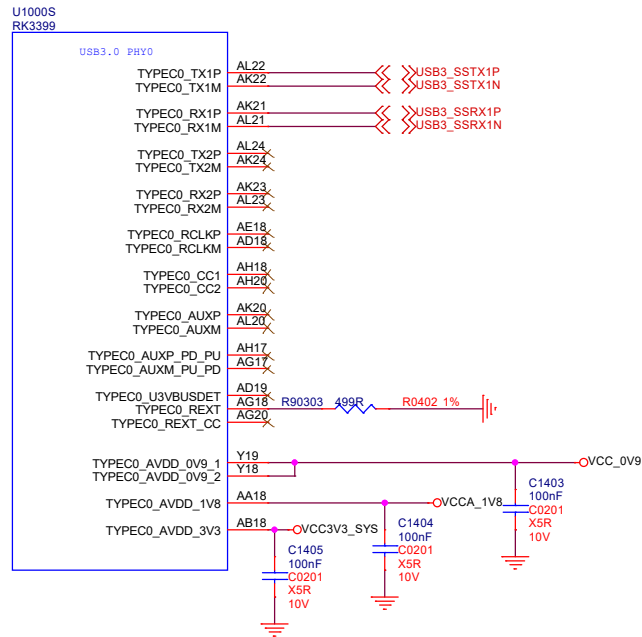

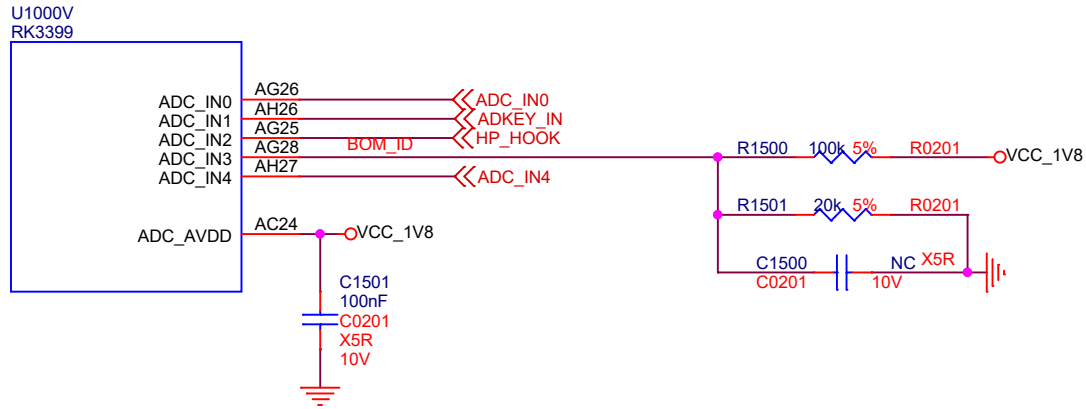

### BOM ID

Item	Rup	Rdown		VOL	VERSION
LEVEL1	DNP	100K		0V	A
LEVEL2	100K	20K		0.3V	B
LEVEL3	100K	51K		0.6V	C
LEVEL4	100K	100K		0.9V	D
LEVEL5	100K	200K		1.2V	E
LEVEL6	100K	499K		1.5V	F
LEVEL7	100K	DNP		1.8V	G



Size	Title: <b>ROCK 4 SE</b>	REV
A4	Page Name: <b>RK3399 SARADC/Key</b>	1.53
Date: <b>Thursday, October 27, 2022</b>	Sheet <b>11</b> of <b>27</b>	

U1000L  
RK3399

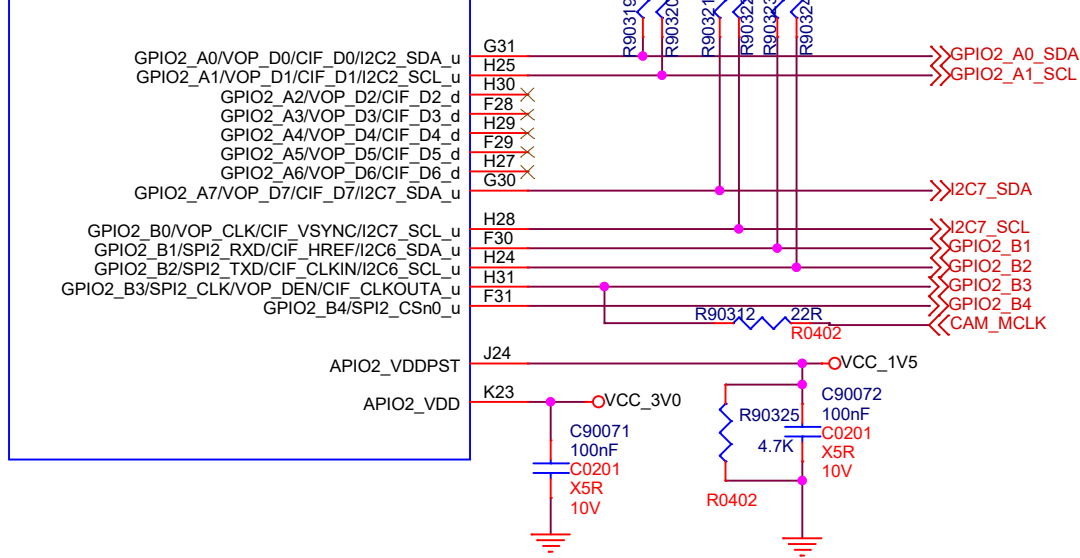

U1000R  
RK3399

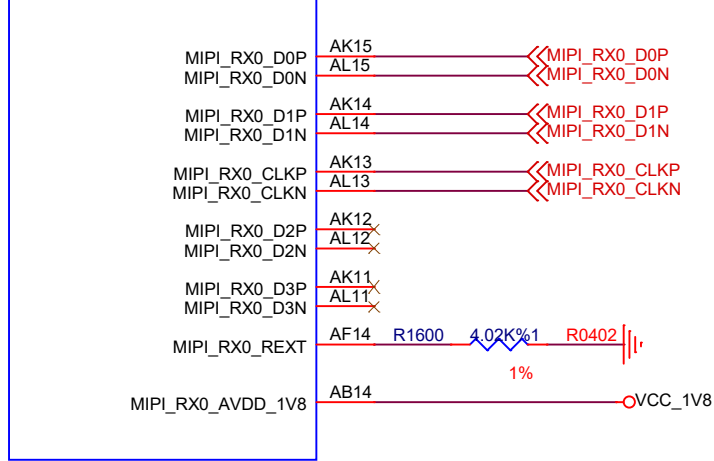

U1000P  
RK3399

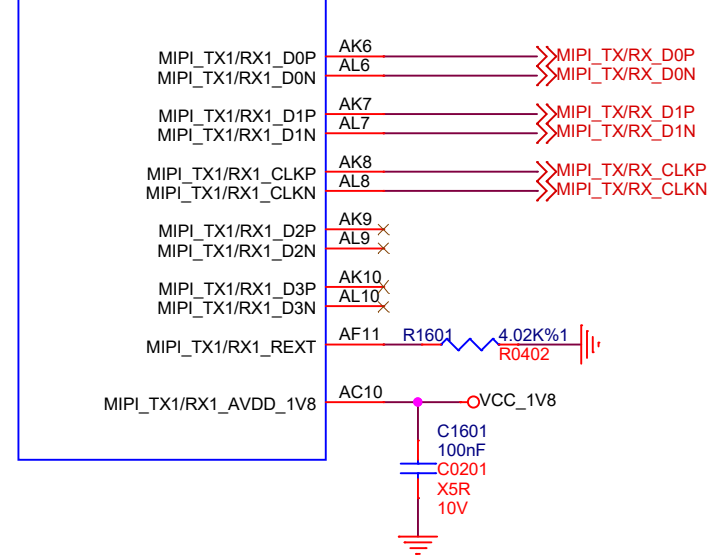

Size	Title: <b>ROCK 4 SE</b>	REV
A4	Page Name: <b>RK3399 DVP Interface</b>	1.53
Date: <b>Thursday, October 27, 2022</b>	Sheet <b>12</b> of <b>27</b>	

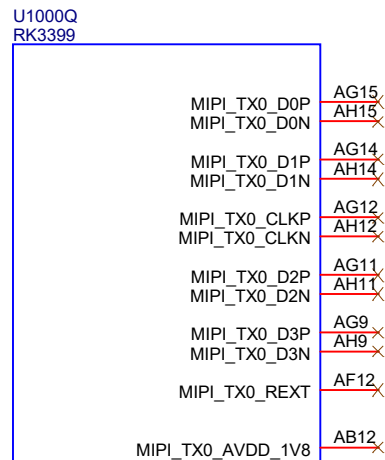
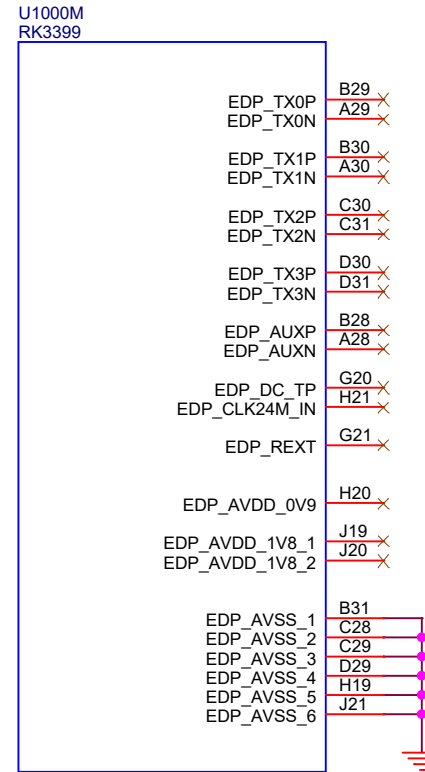
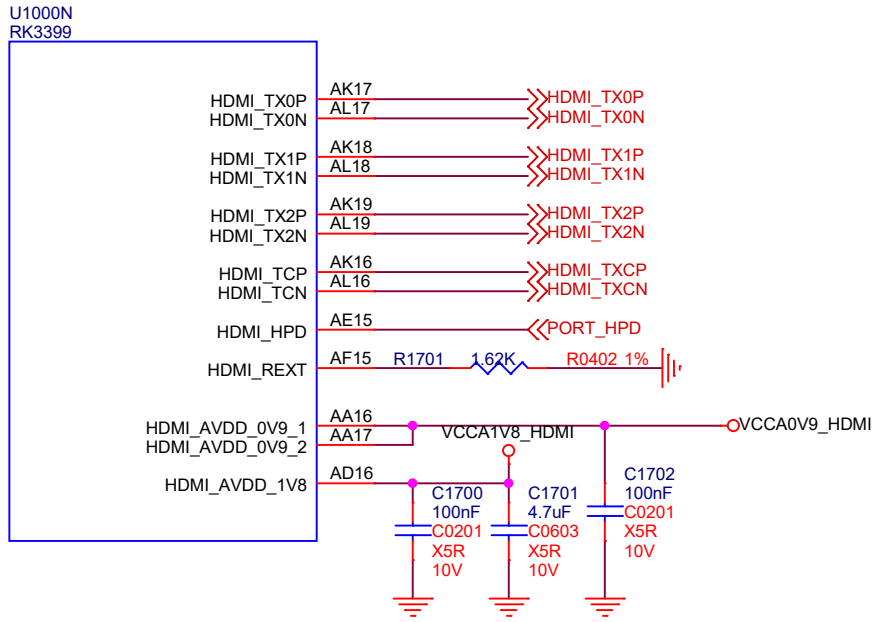

radxa

Size	Title: <b>ROCK 4 SE</b>	REV
<b>A4</b>	Page Name: <b>RK3399 Display Interface</b>	<b>1.53</b>
Date: <b>Thursday, October 27, 2022</b>	Sheet <b>13</b> of <b>27</b>	

U1000I Note:RK3399 part I is 3.3V only  
RK3399

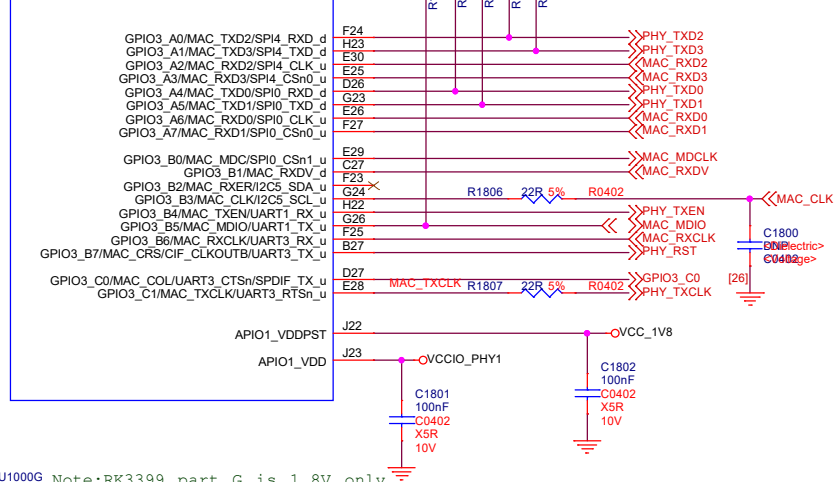

U1000E Note:RK3399 part E is 1.8V/3.0V mode  
RK3399

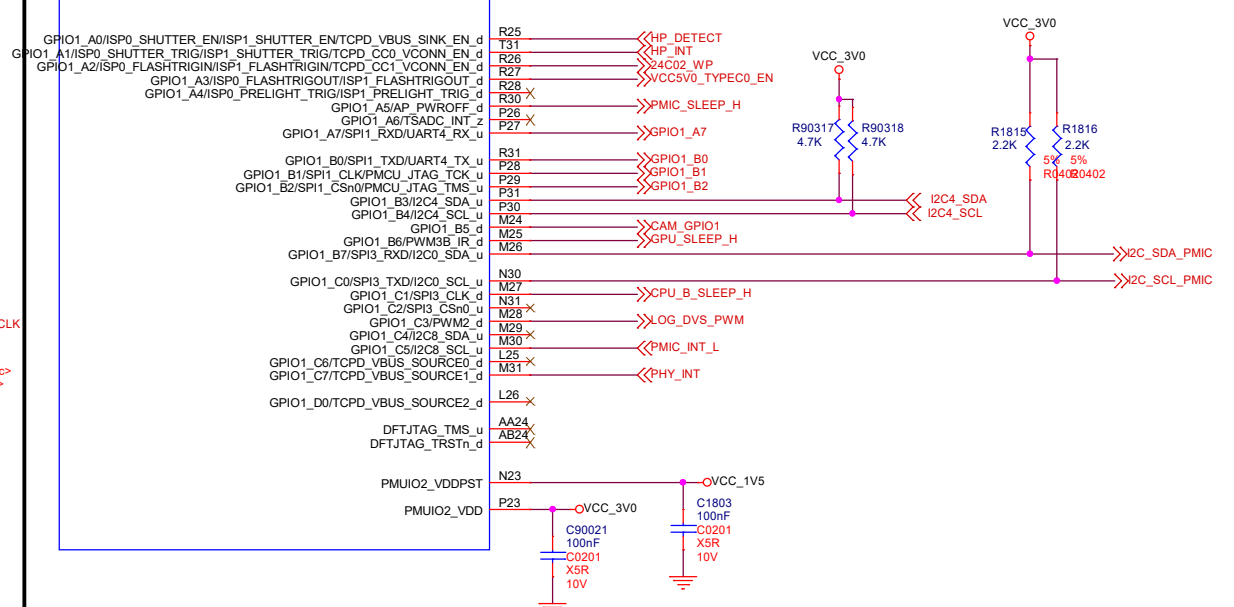

U1000G Note:RK3399 part G is 1.8V only  
RK3399

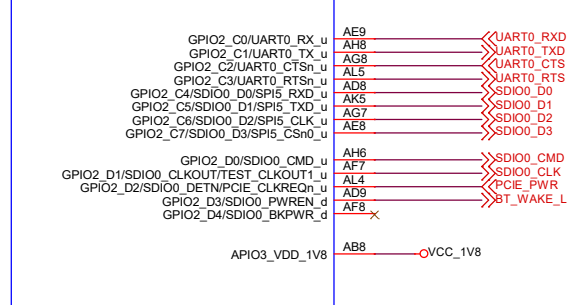

U1000K Note:RK3399 part k is 1.8V/3.0V mode  
RK3399

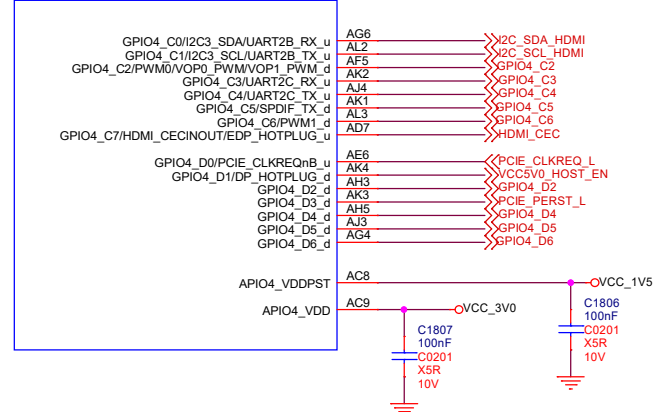

U1000J Note:RK3399 part J is 1.8V/3.0V mode  
RK3399

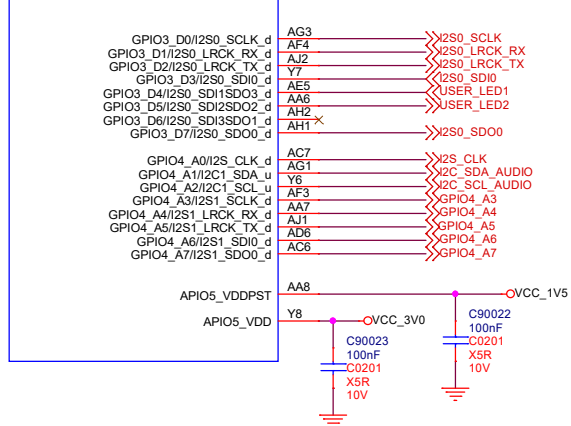

U10000  
RK3399

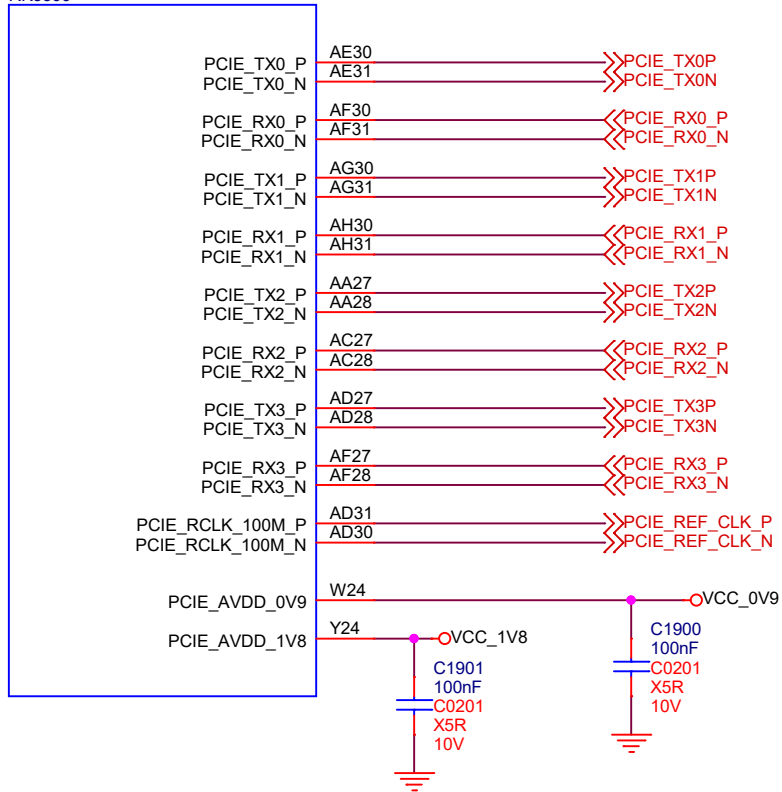

Size	Title: <b>ROCK 4 SE</b>	REV
<b>A4</b>	Page Name: <b>RK3399 PCIE</b>	<b>1.53</b>
Date: <b>Thursday, October 27, 2022</b>	Sheet <b>15</b> of <b>27</b>	





### PMIC

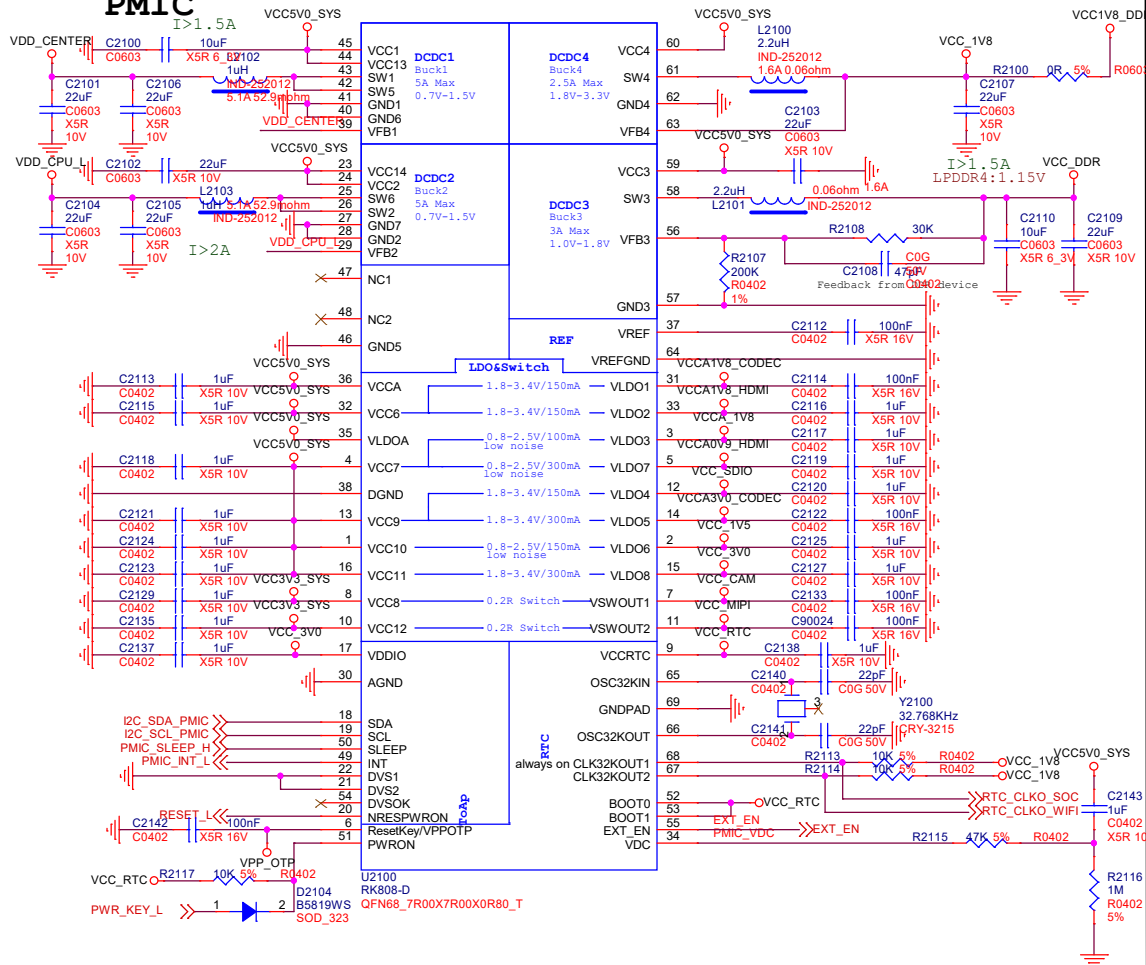

### VDD\_CPU\_B power

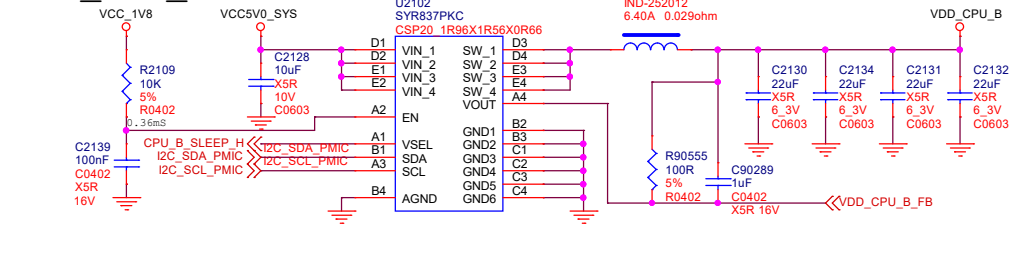

### VDD\_GPU power

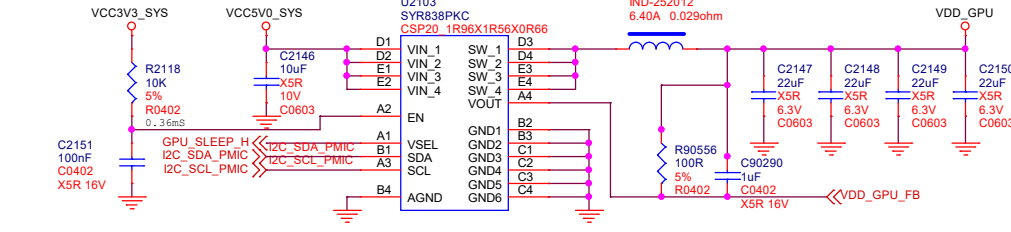

### VCC3V3\_SYS power

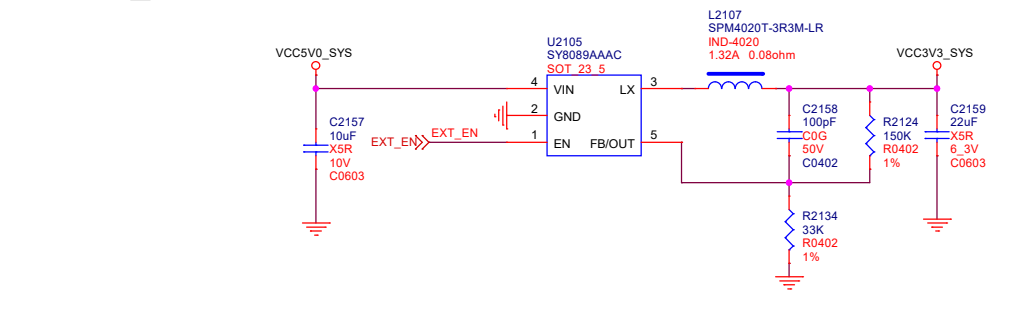

### VCC\_0V9 power

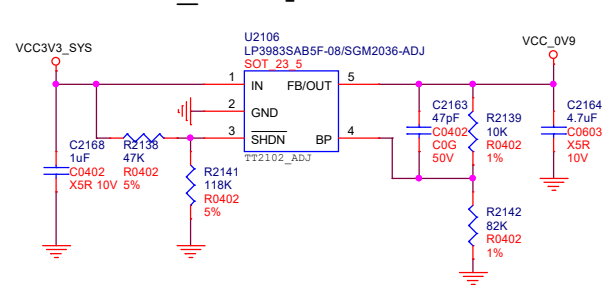

### VDD\_LOG power

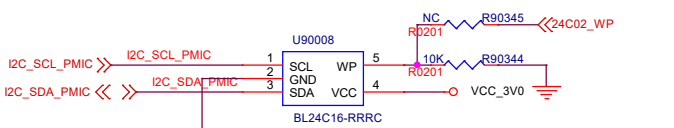
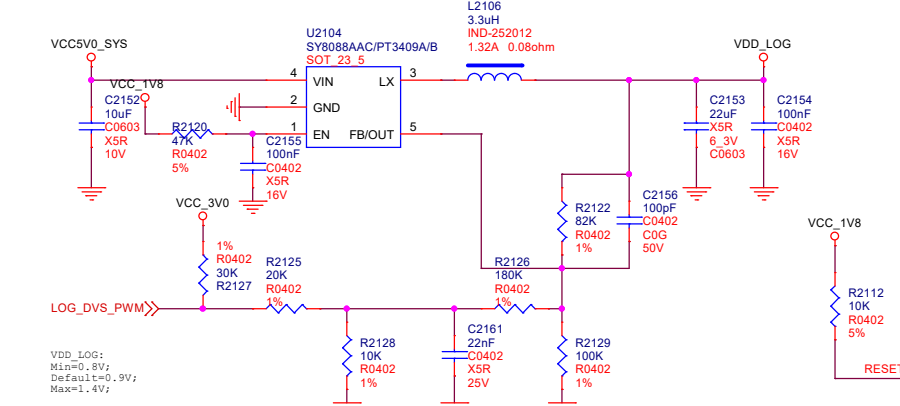

### ID Number

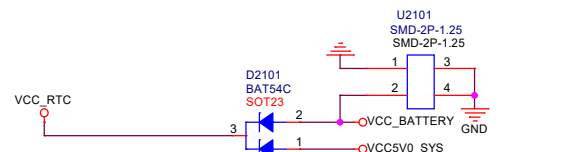

Size	Title:	ROCK 4 SE	REV
A3	Page Name:	Power-PMIC RK808-D	1.53
Date:	Thursday, October 27, 2022	Sheet	17 of 27

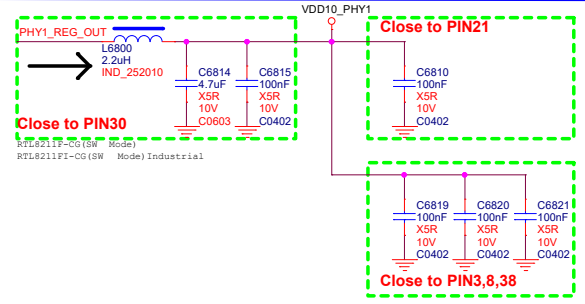
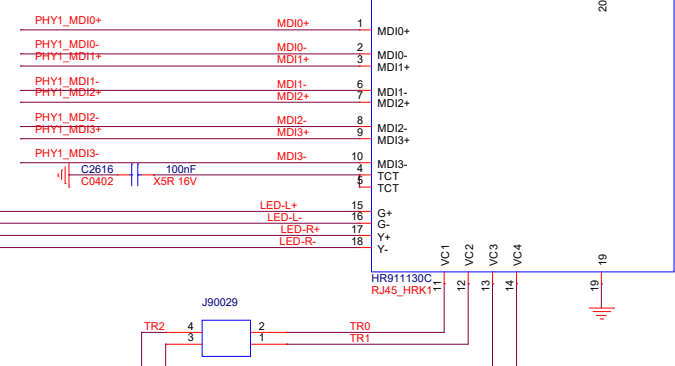
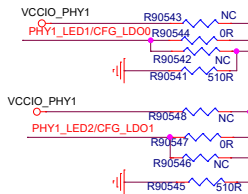
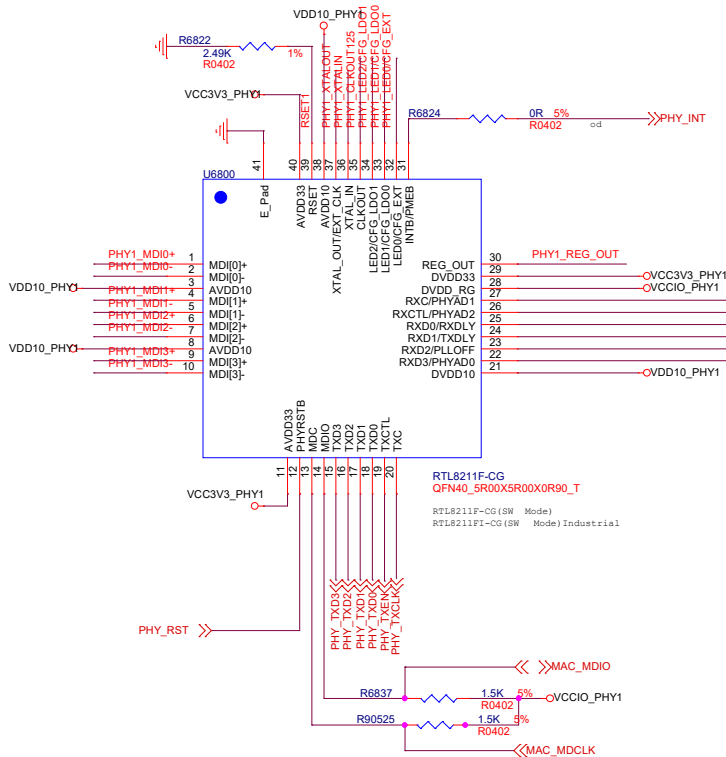
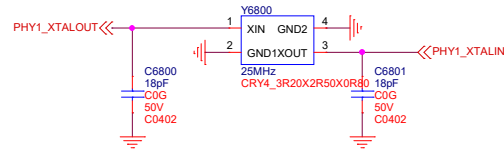
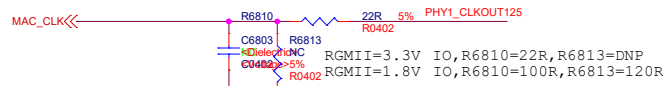

### VCC\_PHY0\_IO Voltage Config

RGMII Power Source	CFG_EXT	CFG_LDO[1:0]
External 3.3V	1'b1	2'b00
External 1.8V (default)	1'b1	2'b10
Internal 1.8V	1'b0	2'b10

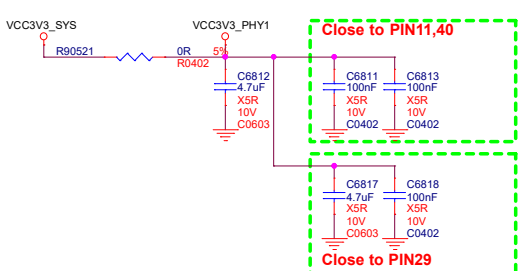
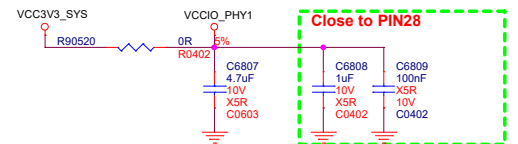
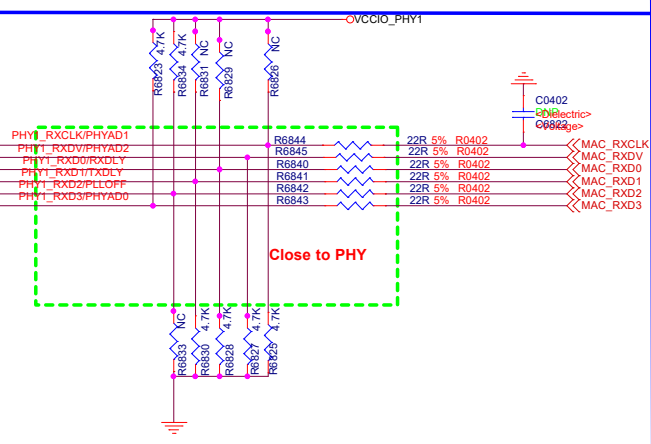
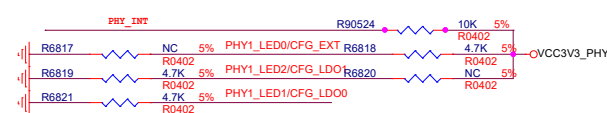





# eMMC

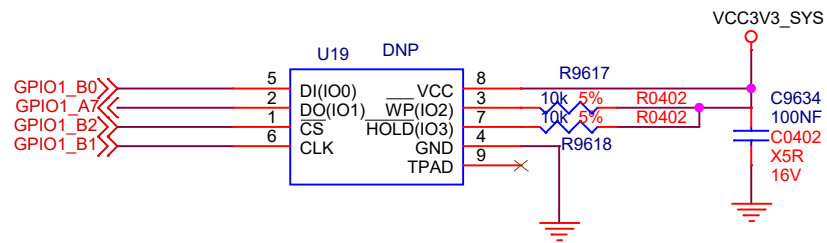
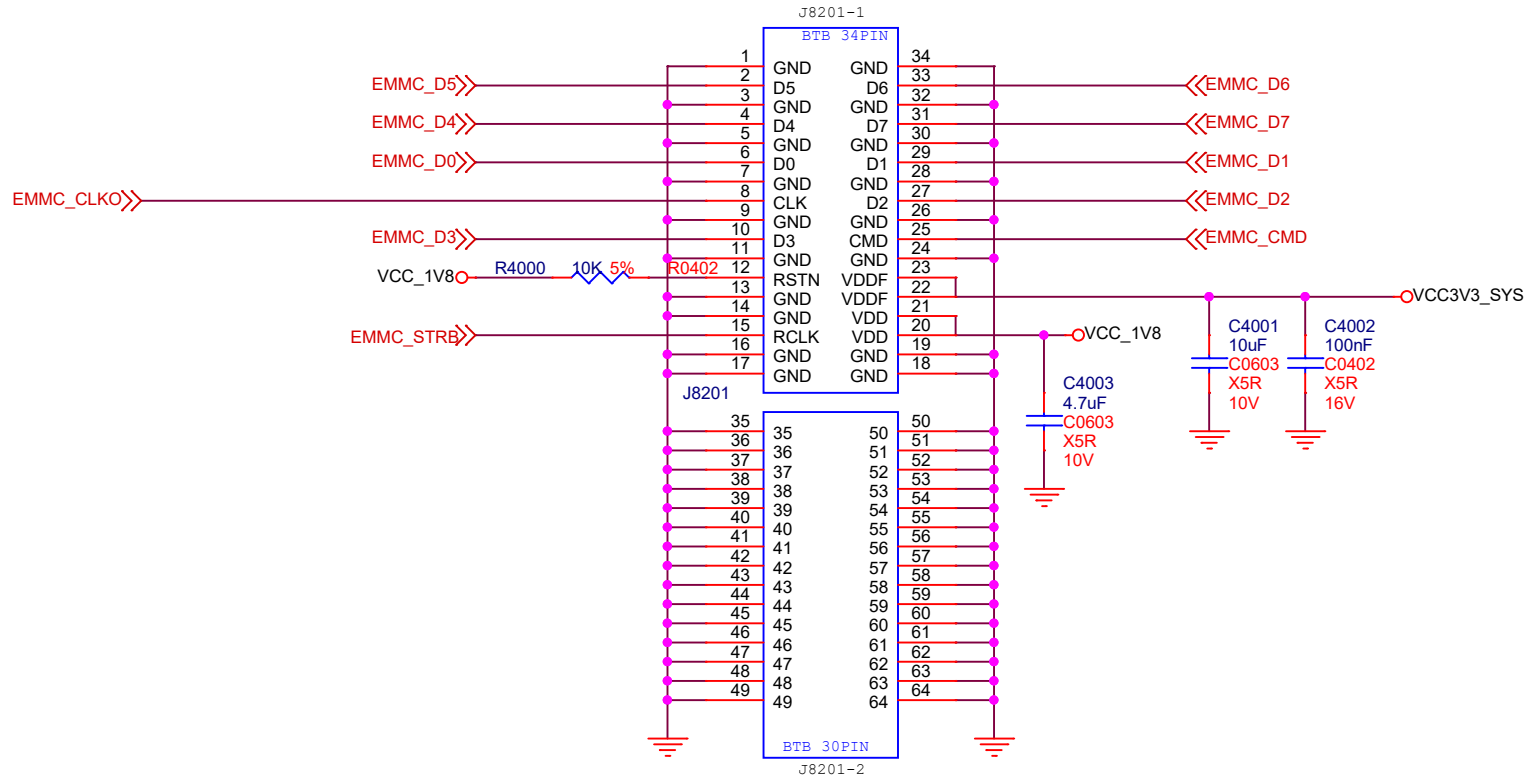

Size	Title: <b>ROCK 4 SE</b>	REV
A4	Page Name: <b>Memory-eMMC</b>	1.53
Date: <b>Thursday, October 27, 2022</b>	Sheet <b>21</b> of <b>27</b>	



# TF CARD

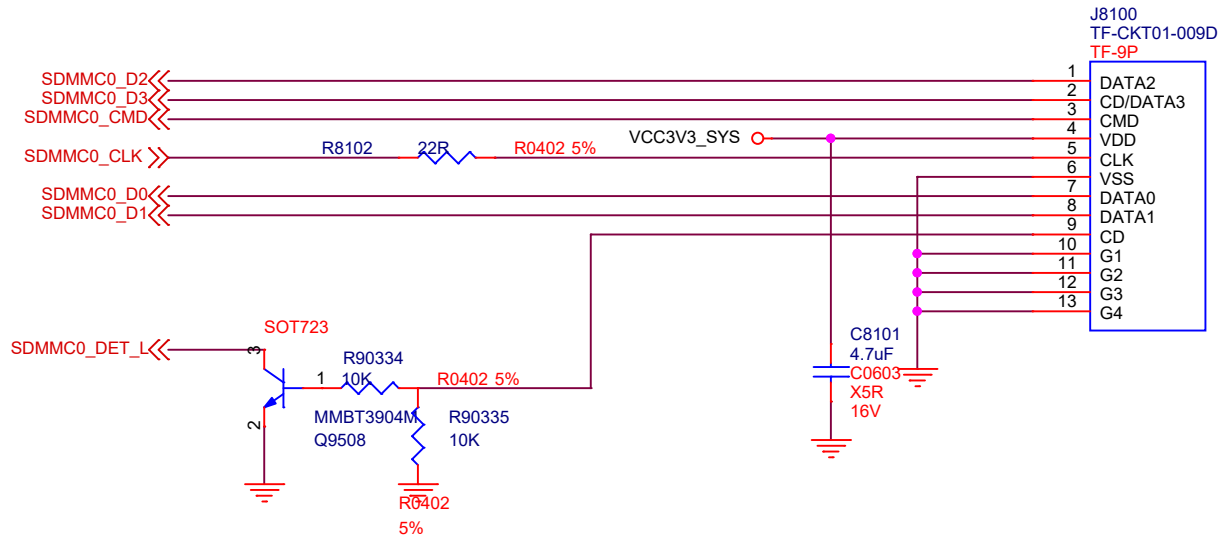

Size	Title: <b>ROCK 4 SE</b>	REV
<b>A4</b>	Page Name: <b>TF Card</b>	<b>1.53</b>
Date: <b>Thursday, October 27, 2022</b>	Sheet <b>23</b> of <b>27</b>	

# HDMI Output

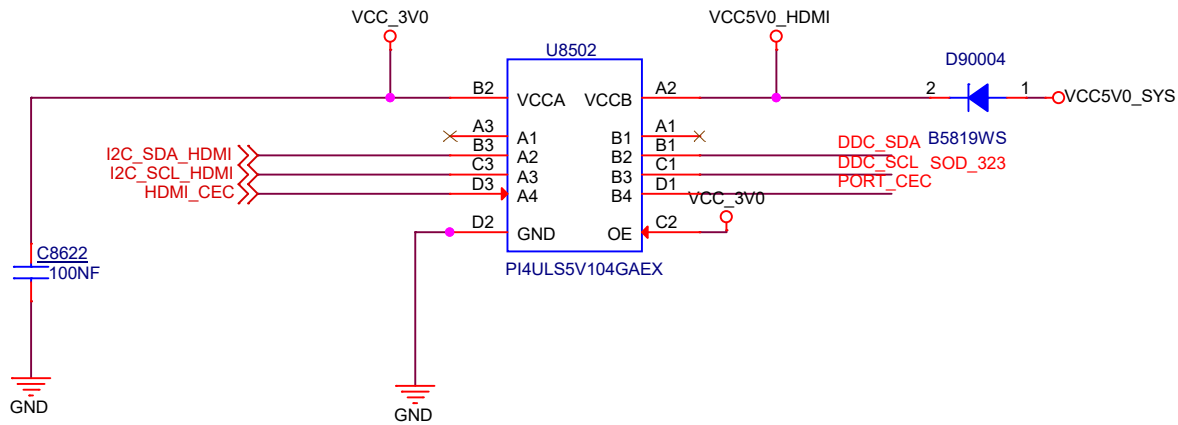
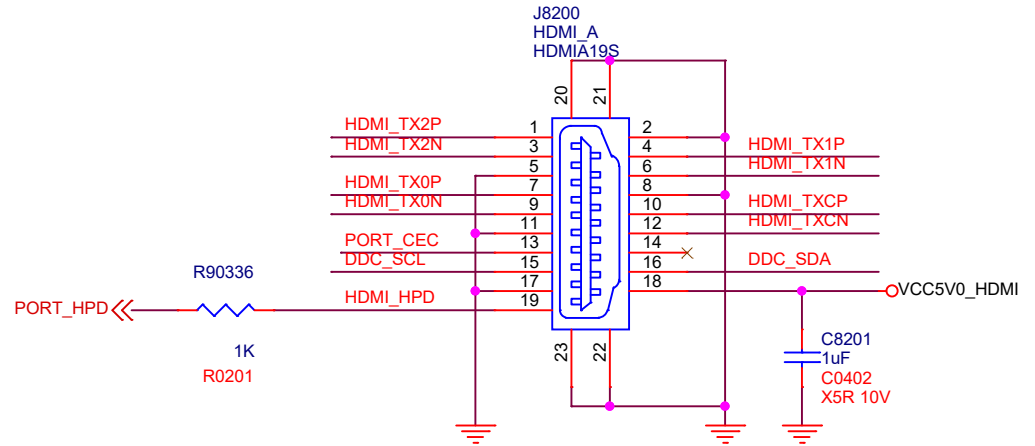
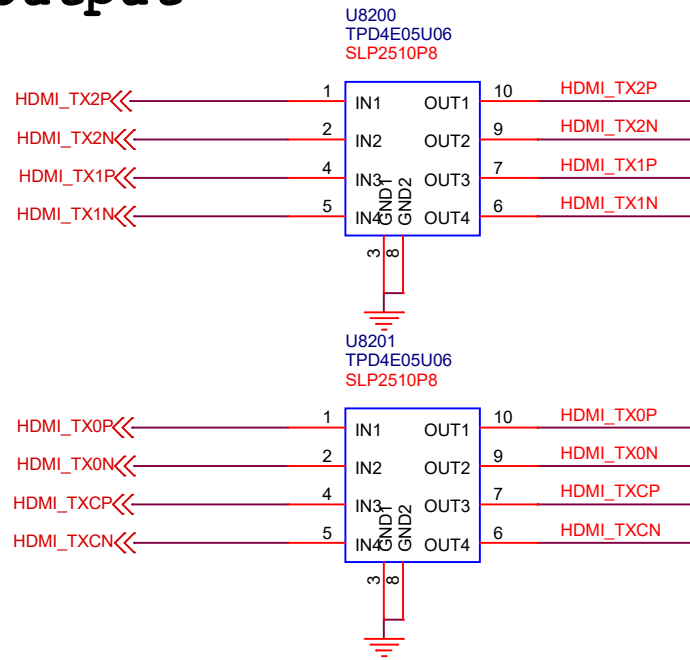

Size	Title: <b>ROCK 4 SE</b>	REV
A4	Page Name: <b>HDMI Output</b>	1.53
Date: <b>Thursday, October 27, 2022</b>	Sheet <b>24</b> of <b>27</b>	



# PCIe NGFF/M.2

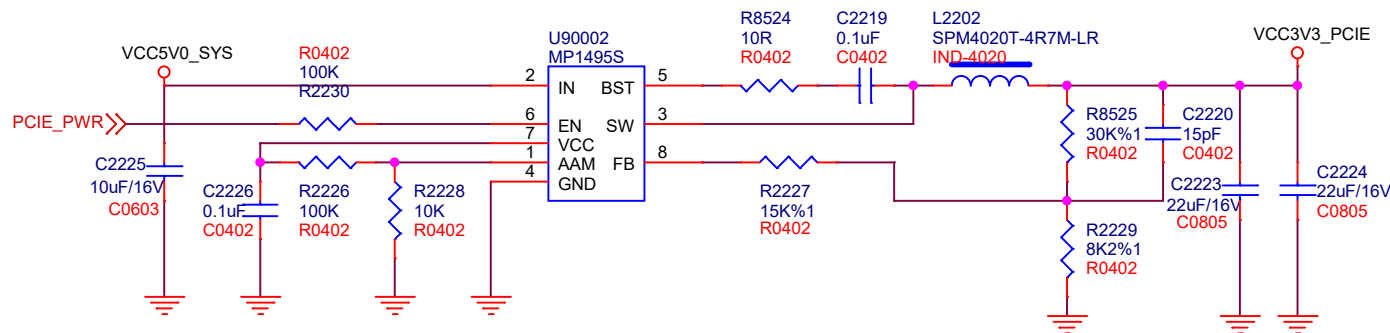
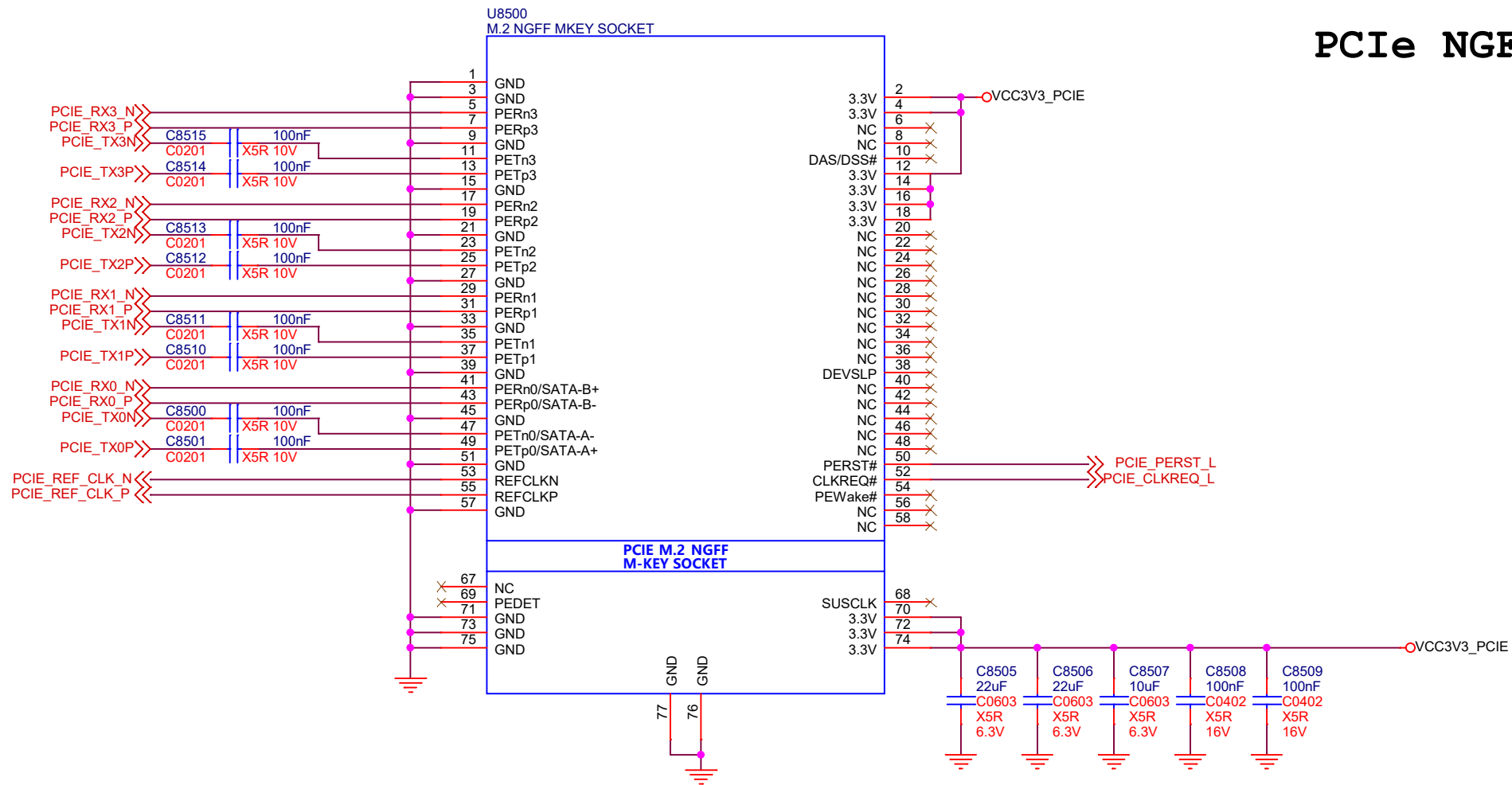

Size	Title: <b>ROCK 4 SE</b>	REV
A4	Page Name: <b>PCIe NGFF/M.2</b>	1.53
Date: <b>Thursday, October 27, 2022</b>	Sheet <b>25</b> of <b>27</b>	

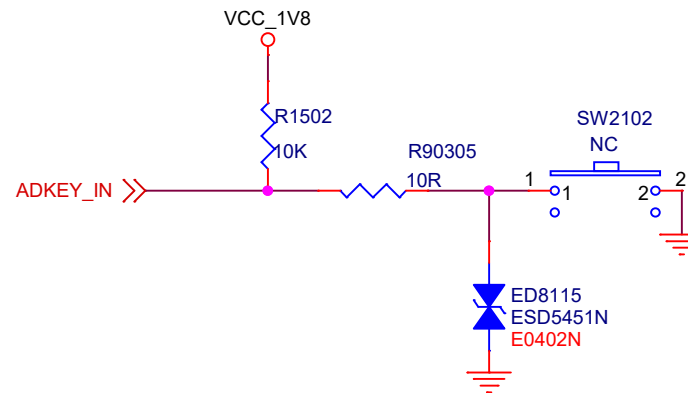
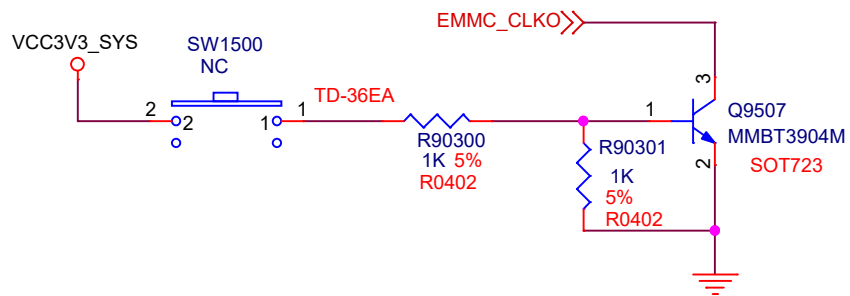
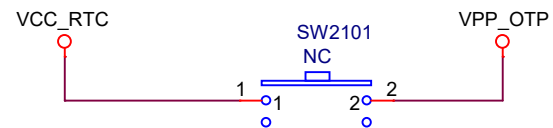
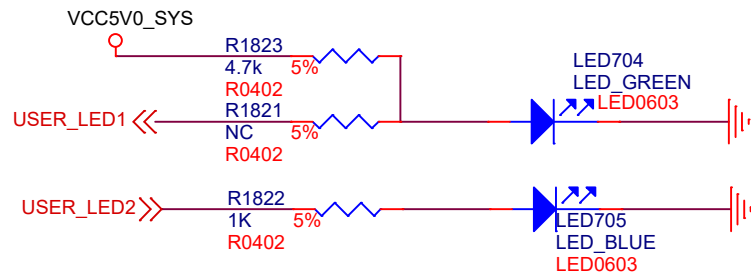

Size	Title: <b>ROCK 4 SE</b>	REV
<b>A</b>	Page Name: <b>FAN-KEY-LED</b>	<b>1.53</b>
Date: <b>Thursday, October 27, 2022</b>	Sheet <b>26</b> of <b>27</b>	

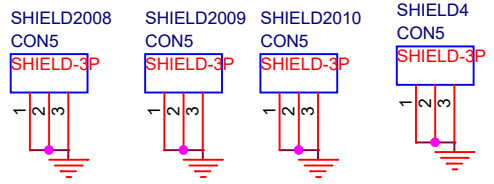
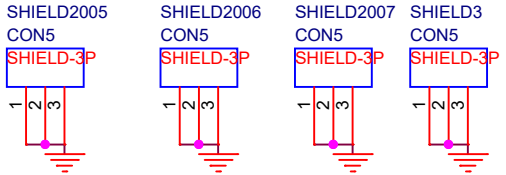
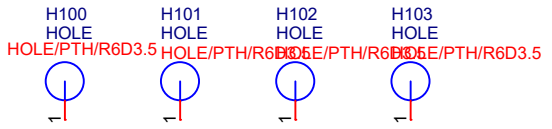

Size	Title: <b>ROCK 4 SE</b>	REV
A4	Page Name: <b>HOLE</b>	1.53
Date: <b>Thursday, October 27, 2022</b>	Sheet <b>27</b> of <b>27</b>	